

ET1243C

Mini IP over Coax Transmitter. Use with ER8200C, ER16200C and ER2400C Receivers only.

The ET1243C is the far end transmitter in an EtherStretch Lyte link and connects to the far end PoE-powered 10/100 Ethernet device. The ET1243C provides 100Mbps Ethernet link extension of up to 350m over RG-59 or RG-6 coaxial cabling. The ET1243C communicates with a multi-channel receiver at the headend.

Each EtherStretch Lyte channel is designed to allow the Ethernet PoE Switch to negotiate with the remote PoE device through the receiver channel, ET1243C transmitter and coaxial cabling. Once the PoE comes up, the receiver channel and ET1243C transmitter also power up and begin link operations. The transmitter will run on 15VDC from the receiver if PoE is not being used on that channel.

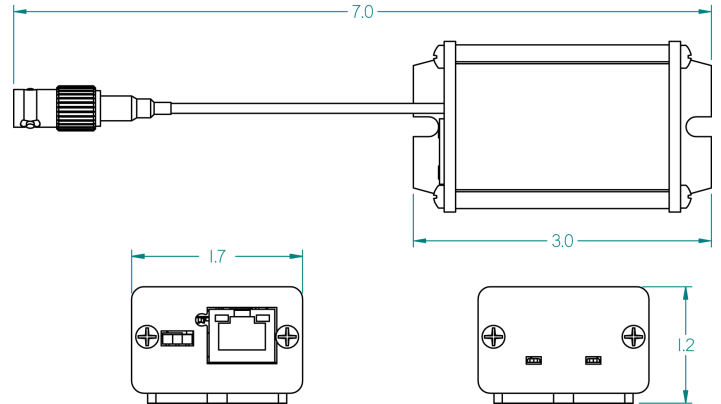

PRODUCT FEATURES

- Mini IP over Coax Transmitter, fits into tight spaces
- Requires ER8200C, ER16200C or ER2400C receiver
- Extends 100Mbps Full Duplex Ethernet & PoE up to 350 meters over coax
- Supports any IP network device & 4K cameras
- Supports IEEE802.3at (25.5W) and IEEE802.3af (15.4W)
- Fully transparent to the network, no MAC or IP addressing required
- LED indicators for power, link status, and PoE output
- Surge protected inputs
- Ground loop isolation
- Easy to set up and install
- Limited Lifetime Warranty
- Designed, tested, manufactured, and supported in the U.S.A.

TECHNICAL SPECIFICATIONS

Max Operating Distance

Network Port: 100m
Link Port (over Coax): 350m

Power

Requirements: PoE passthrough or by 15VDC from the receiver

LED Connectivity Indicators

Power, link status, and PoE output

System Latency

System Latency: <1mS over 350m RG-59

Mechanical Dimensions (W x H x L)

43mm x 30mm x 76mm (1.7" x 1.2" x 3.0" (7"))

Shipping Dimensions (W x H x L)

Package: 27mm x 51mm x 127mm / 5"x 2" x 7.5"

Weight: 0.45kg / 1lbs

Environmental / Temperature

Operating: -40°C to 75°C / -40°F to 167°F
Storage: -40°C to 85°C / -40°F to 185°F
Humidity: Up to 95% non-condensing

Connectors

Network Port: RJ45 Connector
Link Port: BNC Coax Jack on mini cable

Rating / Listing

UL: IEC/UL 60950-1
NEMA TS-2: Temperature & Humidity NEMA 2.2.7
Mechanical Vibration NEMA 2.2.8
Mechanical Shock NEMA 2.1.2
Operating Frequency NEMA 2.1.3
Transient Test NEMA 2.1.6 thru 2.1.8

NITEK®

5410 Newport Drive
Rolling Meadows, IL 60008
www.nitek.net

800.528.4343 toll free
847.259.8900 tel
info@nitek.net email

